

(**): signalling depends on a test being executed at the moment, as in a given test

CT central test version

This version in a basic make is designed for co-operation with a WELLS wireless central monitoring system. All control possibilities are described in a separate instruction manual dedicated for WELLS system. Signalling ways of all luminaire's states and tests' schedules and results are identical to those described for AT version. Additional states are described below. An "UNBOUND" signal means that a luminaire is not (temporarily or permanently) in a communication contact with a control unit:

LUMINAIRE WORKING STATE OR ACTION	GREEN LED INDICATION	RED LED INDICATION	COMMENTS
WELLS COMMUNICATION STATES			
„UNBOUND” SIGNAL, 24h AFTER LOSS OF COMMUNIC. WITH A CENTRAL UNIT	FLASHING (6/T2)	FLASHING (6/T2)	SIMULTANEOUS

FLASHING (6/T2) – 6 quick consecutive simultaneous pairs of green LED and red LED flashes, repeated in a 10s period, the sequences interrupt signalling of a basic luminaire's state (according to the table described for AT)

IMPORTANT – for a luminaire not connected with a central unit (wireless network) it means only no connection between the luminaire and the central unit. The luminaire can be still working correctly, performing planned tests and signalling their results on signal LEDs, assuring safety of a building, but tests' results are not being transferred to a central unit.

FAULTY OPERATION AND ITS POSSIBLE DIAGNOSIS

LED indicator does not light up

AC power failure.

LED indicator is red, the luminaire does not operate (MT version, e.g. in SA / M mode)

Possible damage of one of a luminaire's elements: a charging circuit, a light source supply circuit, a light source itself, a battery or an autonomy operation in an emergency mode is too short. It is recommended to repeat the test and - in a case of confirmation of bad results to call a service team. For more information, please, refer to the "TESTING" section.

LED indicator blinks red

The luminaire performs testing. Please, refer to the "TESTING" section.

The luminaire does not operate in emergency mode the required time for a selected model

It is possible that the battery requires a full charge cycle (24h). If after 24 hours of charging the luminaire still does not keep a predefined autonomy, it is possible that the battery is run-down or damaged, e.g. due to possible incorrect formatting and needs to be replaced.

RECOMMENDED PERIODICAL MAINTENANCE

The luminaire should be tested on regular basis in accordance with valid laws and regulations. The results of the tests should be recorded and stored for the use of a fire safety inspector.

One time daily

It is suggested to check visually if the LED indicator in the luminaire lights up in green.

One time each month

It is necessary to perform a function test by disconnecting the AC power supply and checking whether the luminaire is operating in emergency mode - the green LED indicator should turn off, and LED light source light up. For an MT version the test is being performed manually, for AT and CT versions is being performed automatically, according to programmed cycles.

One time each year

In order to make an autonomy test, disconnect the AC power supply and test if the luminaire operates in emergency mode for a specified time. If the autonomy time of emergency operation is not sufficient, the battery needs to be fully recharged and the test is to be carried out again. If the result of the test continues to be negative, the battery needs to be replaced. For an MT version the test is being performed manually, for AT and CT versions is being performed automatically, according to programmed cycles.

CAUTION!

All damage that might occur as an effect of the device being used not in accordance to this instruction will result in loss of guarantee.

Used or damaged lamps including batteries, are subject to be recycled. They should be delivered to the point of collection of electrical and battery waste or to the manufacturer.

Handling of obsolete equipment



Pursuant to the Act of 29 July 2005 on waste electrical and electronic equipment and the Act of 24 April 2009 on batteries and accumulators, the presented device, after use, due to hazardous substances contained in it, is subject to collection of waste electrical and electronic equipment. Detailed information on WEEE collection can be obtained from municipal authorities.

intelight

Intelight Sp. z o.o.
19, Gwiaździsta str.
01-651 Warsaw, Poland

intelight

PRIMUS LED HP EMERGENCY KIT

Installation and maintenance instructions



PRIMUS LED HP module

LiFePO4 battery pack

Version:

PRIMUS LED HP

TECHNICAL SPECIFICATIONS:	
Application for light source type:	LED
Operating modes*:	SA (M) – mains and emergency operation or A (NM) – emergency operation
Test versions**:	AT – auto test or CT – central test
Emergency autonomy***:	1h, 2h, 3h or 8h
Output power***:	3W, 6W, 9W or 12W
Battery packs to be used (replaceable):	Maintenance free lithium-iron-phosphate (LiFePO4)
Voltage and battery capacities***:	12.8V 600mAh ÷ 10000mAh
Battery charging duration max.:	24h
Converter working frequency:	20kHz ÷ 40kHz
Mains to emergency switching time:	0,2s ÷ 0,8s
Power supply:	220-240VAC 50Hz
Power consumption max.***:	3W ÷ 10W
Module:	Primus LED HP
Working point temperature (Tc):	70°C
Ambient temperature (Ta):	5°C ÷ 50°C
Housing colour:	white
Housing IP rating:	IP20
Module dimensions (w/o battery pack):	LxWxH: 152x42x32mm
Installation way:	By means of screws, inside of a lighting fixture

* - depending on wiring

** - depending on model

*** - depending on settings



INTRODUCTION

1. The emergency module inside a luminaire and the luminaire itself should be installed when power supply is off. Safety rules, construction and electrical installation standards should be followed all the time.
2. The luminaire should not be powered with circuits connected to inductive power-receiving devices at the same time. This type of solution may cause damage to the electronic module of the luminaire.
3. The emergency module should be installed inside a luminaire or close to it, in the latter case the luminaire should be used indoors.

INSTALLATION

1. Before installation one has to make sure that the luminaire will be connected to 220-240VAC power supply by the use of minimum a 1,5mm² wire.
2. Installation of the emergency module inside a luminaire can be made by means of screws Ø 4mm max. Battery pack should be installed firmly so that it couldn't move freely inside the luminaire.

3. For emergency module with luminaire's elements wiring one need to use one of the below wiring schemes:

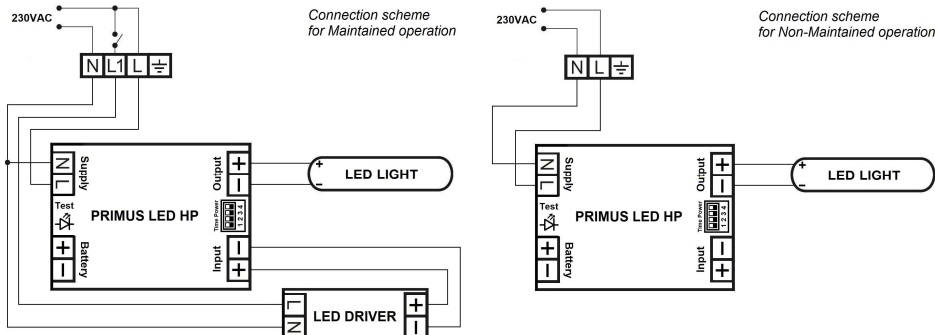

4. Connect all the wires of a prepared power cable to the appropriate terminal block entries.
5. The description of luminaire's terminals:
L - phase wire - brown or black insulation colour; power source for battery charging, presence signalled by signal LED lighting up in green;
L1 – a terminal to be optionally used for a wall switch connection, enabling to switch a luminaire off during M mode operation, if no switch is used the terminal L1 should be connected to a phase wire in parallel with the L terminal;
N - neutral wire - blue insulation colour.
6. **Luminaire designed for EMERGENCY operation (A, NM).** To wire a luminaire designed for a Non-Maintained operation, AC mains power has to be connected to appropriate terminals: L (phase) and N (neutral). The luminaire should be constantly supplied by power - voltage drop on L will result in emergency mode activation. (see the right scheme in point 3 above)
7. **Luminaire designed for MAINS AND EMERGENCY operation (SA, M).** To wire a luminaire designed for a Maintained operation, AC mains supply needs to be connected to appropriate terminals: L (phase), N (neutral) and L1 (wall switch wire). L1 terminal can be optionally connected through a wall switch, enabling switching the luminaire off for a time (the luminaire stays ready for an emergency operation). The luminaire should be constantly AC supplied, phase loss on L will cause automatic activation of the emergency mode. (see the left scheme in point 3 above)
8. Depending on the desired emergency power and duration, set the dip switches according to the pattern on the right (Power = emergency power / switches 3&4; Time = emergency duration / switches 1&2):
9. The testing button and two signal LEDs should be installed in the luminaire so that they are visible (LEDs) and accessible (test button). If the luminaire is to keep higher IP level it is recommended either to install them behind the luminaire's diffuser or to protect installation holes by appropriate gaskets or washers.
10. Before connecting the luminaire to the mains network, insert the white battery plug into the socket in the module.
11. Please remember to indicate the date of installation on the label attached to the battery pack.
12. For quick operation testing – switch on the AC power supply. The green LED indicator should light up, signaling the mains connection and battery charging. After battery is charged, the LED indicator should still light up in green, what means readiness for emergency operation. By pressing the test button, one can check if the luminaire enters the emergency operation when the power supply is off. The way how to press the test button and how to read the luminaire's behaviour depends on its version. You can find detailed information in the "TESTING" section.
13. First-time charge of the luminaire battery pack should be carried out continuously for 48 hours. This will allow appropriate formatting of the battery pack. During the first-time charge, no testing should be carried out and power supply should not be disconnected for any other purpose. Power supply should be disconnected after 48 hours for the first time. The luminaire should complete a full emergency operation cycle, after which it should be connected to power supply for another 36 hours. This sequence shall complete the formatting cycle.

Time	Power
1H	3W
2H	6W
3H	9W
8H	12W

OPERATION

Emergency operation mode

In this mode (A, NM) the luminaire does not light when powered by AC supply voltage. Correct operation of the device is confirmed by LED indicator lighting up in green. The battery is being continuously trickle charged for the purpose of a possible emergency operation. When AC power supply is off (no voltage on L), the luminaire automatically starts operating in emergency mode and the source of light is activated for the period specific for a particular model. During emergency operation, the LED indicator is off.

Mains and emergency operation mode

In this mode (SA, M) the luminaire lights up when powered by AC supply voltage. Correct operation of the device is also confirmed by LED indicator lighting up in green. The battery is being continuously trickle charged for the purpose of possible emergency operation. When AC power supply is off (no voltage on L), the luminaire automatically starts operating in emergency mode and the source of light is activated for the period specific for a particular model. During emergency operation, the LED indicator is off.

Information on lamp operation

The green LED indicator signals connection to a mains network. For a luminaire installed properly it means that a battery is being continuously charged / trickle charged. If the green indicator does not light up, it may mean that the lamp is not operating with AC power supply on or any luminaire's element (e.g. the battery) has been damaged. See more info about signaling in "TESTING" section.

Battery pack

The emergency set is equipped with a rechargeable lithium-iron-phosphate LiFePO4 battery pack. Please remember to carry out the correct first-time charge cycle (see "INSTALLATION", p.13). After such a formatting cycle it achieves its capacity and is prepared to perform a possible full time emergency operation. It is suggested to discharge and then to re-charge the battery every three months, even if it hasn't been used, in order to extend its performance. It is recommended to replace the battery once every four years of operation or in a case of poor test results. Obsolete batteries, similarly to packaging, fluorescent lamps or electronics, are recyclable products that should be disposed to a recyclable waste collection point.

TESTING

A luminaire equipped in PRIMUS LED HP module can be equipped in either auto AT or central CT test, depending on model. The module is equipped with a test button that can be optionally used for manual tests' initiations. It enables to check the readiness for emergency operation at any time, apart from planned tests. NOTE! – if such an optional test is finished less than 24h before any planned test, the planned test will be delayed in order to achieve full 24h battery charging time. The delay will be applied also in a case of mains failure and its restoration at the moment that is closer than 24h before such a planned test.

AT auto test function

If a luminaire version has an auto test functionality, the TEST button is being used to initiate and break either function or autonomy tests. When the luminaire is connected to mains network and there is no voltage drop, pressing and holding the test button, depending on time of pressing, will result in activation of any of the two. Pressing the button for more than 2s and not longer than 5s (2s<t<5s) initiate the function test, for more than 10s and not longer than 15s (10s<t<15s) – initiate the autonomy test. For a convenient counting of seconds – when a test button is pressed and hold – after every second the luminaire confirms the passing time by a quick flash of a red indication LED. When the luminaire is during any (manually initiated) test procedure, pressing the button for a time longer than 10s (t>10s) – breaks any currently running test.

In a standard luminaire's operation, both functional and autonomy tests are being initialised automatically, function test every 28 days and autonomy test every 336 days. There is no possibility to break any automatically planned test. There is also no possibility to erase any test results, this means that any signalled failures will be cancelled only after making the luminaire repaired.

IMPORTANT – in a case of a power failure happening while a test is being performed, the luminaire breaks it, then starts emergency operation. After the emergency operation is finished and after a power return the luminaire won't signal any test's results (only green LED will be on, as in a basic state). The interrupted planned test (if the power failure was shorter than 7 days) shall be repeated after min. 24h after the power return. The test initiated manually won't be repeated.

All the possible luminaire working states and LED indications are gathered in the table below.

LUMINAIRE WORKING STATE OR ACTION	GREEN LED INDICATION	RED LED INDICATION	COMMENTS
BASIC STATES			
MAINS SUPPLY ON, BATTERY BEING CHARGED	ON	OFF	
MAINS SUPPLY FAILURE, EMERGENCY OPERATION	OFF	OFF	
FUNCTIONAL TEST STATES			
FUNCTIONAL TEST - PART 1 (LIGHT SOURCE AND ELECTRONICS)	OFF	FLASHING (1/T2)	DURATION: 60s
FUNCTIONAL TEST - PART 2 (CHARGING CIRCUIT)	ON	FLASHING (2/T)	DURATION: 10s
CHARGING, ELECTRONIC CIRCUIT, LIGHT SOURCE OR BATTERY FAILURE	ON	ON	
LUMINAIRE (ELECTRONICS, BATTERY, LIGHT SOURCE) – OK	ON	OFF	
AUTONOMY TEST STATES			
AUTONOMY TEST - PART 1 (LIGHT, ELECTRONICS, AUTONOMY)	OFF	FLASHING (2/T2)	DURATION: 1h, 2h, 3h, 8h(*)
AUTONOMY TEST - PART 2 (CHARGING CIRCUIT)	ON	FLASHING (2/T)	DURATION: 10s
CHARGING, ELECTRONICS, LIGHT SOURCE, BATTERY OR AUTONOMY FAILURE	ON	ON	
LUMINAIRE (ELECTRONICS, BATTERY, AUTONOMY, LIGHT SOURCE) – OK	ON	OFF	
MANUAL TEST BUTTON FUNCTIONS			
INITIATION OF A FUNCTIONAL TEST – PRESSING A BUTTON FOR A 2s<t<5s	ON	FLASHING (1/T)	FLASHING ENABLES TIME (t) COUNTING
INITIATION OF AN AUTONOMY TEST – PRESSING A BUTTON FOR A 10s<t<15s	ON	FLASHING (1/T)	
BREAKING OF ANY TEST (**) – PRESSING A BUTTON FOR A t>10s	FLASHING (5/T)	FLASHING (***)	

T – 1s period; T2 – 10s period; t – time of pressing the test button

FLASHING: (1/T) / (2/T) / (5/T) – 1 flash / 2 flashes / 5 flashes every 1s period

FLASHING: (1/T2) / (2/T2) – 1 flash / 2 flashes every 10s period

(*): test duration is same as an autonomy time declared for a given luminaire

(**): automatic normative tests cannot be interrupted, it concerns solely manual tests